



- » IIC D Ex tD A22 Tx IP66
- » TÜV NORD TÜV 05 ATEX 2768X
- » Оборудование и защитная система предназначены для использования в потенциально взрывоопасных атмосферах (Зона 22) - Директива 94/9/EC
- » Соответствует основным требованиям по охране здоровья и безопасности IEC 60079-10-2



# СТАНДАРТНАЯ СЕРИЯ MVE



## 6 ПОЛЮСОВ - 1000/1200 об/мин

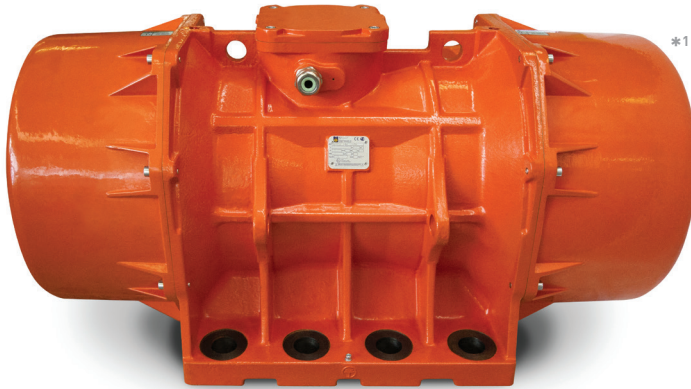

\*1



\*2

Рабочий момент (кгсм)		Модель		Вынуждающая сила (кг)		Вес (кг)		ЭЛЕКТРИЧЕСКИЕ ПАРАМЕТРЫ						СЕРТИФИКАТ		
								Мощность (кВт)		Сила тока A max. (Y)		Ia / In		Уплотнение кабеля	Класс II Разд.2	IIBD
50Hz	60Hz	50Hz	60Hz	50Hz	60Hz	50Hz	60Hz	50Hz	60Hz	50Hz	60Hz	50Hz	60Hz		Метрич.	Темп. класс
9.49	6.59	MVE 50/1	MVE 50/12	53	53	10.4		0.12	0.14	0.40	0.50	2.00	2.00	M20	T4	100°C
18.80	13.18	MVE 100/1	MVE 100/12	105	106	12.2		0.12	0.14	0.40	0.50	2.00	2.00	M20	T4	100°C
33.49	23.38	MVE 200/1	MVE 200/12	187	188	19.6		0.18	0.21	0.53	0.51	2.00	2.00	M20	T4	100°C
56.93	39.85	MVE 300/1	MVE 300/12	318	320	26.6		0.35	0.38	0.67	0.64	2.50	2.50	M20	T4	100°C
91.88	64.32	MVE 500/1	MVE 500/12	513	517	34.0		0.35	0.40	1.20	1.15	2.80	2.70	M20	T4	100°C
91.88	91.88	MVE 510/1	MVE 510/12	513	739	34.5		0.35	0.40	1.20	1.15	2.80	2.70	M20	T4	100°C
137.37	108.58	MVE 800/1	MVE 800/12	767	873	61.8	59.4	0.68	0.76	1.29	1.26	2.80	2.80	M25	T4	135°C
187.69	137.31	MVE 1100/1	MVE 1100/12	1048	1104	79.4	73.0	0.75	0.80	1.42	1.32	3.20	3.10	M25	T4	135°C
284.76	196.51	MVE 1500/1	MVE 1500/12	1590	1580	83.6	76.5	1.10	1.30	2.10	2.00	3.30	3.30	M25	T4	135°C
299.63	203.47	MVE 1600/1	MVE 1600/12	1673	1636	99.8	89.0	1.10	1.30	2.83	3.22	3.70	3.60	M25	T4	135°C
373.05	248.74	MVE 2100/1	MVE 2100/12	2083	2000	114.3	100.5	1.50	1.80	3.00	3.00	4.30	4.40	M25	T4	135°C
467.44	306.70	MVE 2600/1	MVE 2600/12	2610	2466	148.6	131.5	1.96	2.10	3.63	3.38	4.80	4.80	M32	T4	135°C
540.33	379.71	MVE 3000/1	MVE 3000/12	3017	3053	155.4	137.8	2.20	2.40	4.50	4.30	5.00	5.00	M32	T4	135°C
939.60	657.90	MVE 5210/1	MVE 5210/12	5237	5290	225	191	3.80	4	6.92	6.36	5.50	5.50	M25	T4	135°C
680.38	437.41	MVE 3800/1	MVE 3800/12	3799	3517	215.6	194.8	2.50	3.00	4.67	4.88	5.90	6.00	M32	T4	135°C
838.34	584.17	MVE 4700/1	MVE 4700/12	4681	4697	230.8	212.4	3.20	3.90	6.50	6.00	5.50	5.70	M32	T4	135°C
929.86	654.57	MVE 5200/1	MVE 5200/12	5192	5263	279.8	264.2	3.80	4.00	6.92	6.36	5.50	5.50	M32	T4	135°C
1165.19	823.96	MVE 6500/1	MVE 6500/12	6506	6625	304.4	280.7	4.30	5.00	7.76	7.81	6.20	6.00	M32	T4	135°C
										A max. (Δ)						
1435.98	929.80	MVE 8000/1	MVE 8000/12	8018	7476	325.2	290	7.10	7.50	12.60	11.60	6.00	6.20	M32	T4	135°C
1600.39	1165.23	MVE 9000/1	MVE 9000/12	8936	9369	337.8	307.6	7.50	8.30	13.20	12.60	6.30	6.20	M32	T4	135°C
1788.44	1239.98	MVE 10000/1	MVE 10000/12	9986	9970	385.8	359.3	7.60	8.00	13.50	12.70	6.40	6.40	M32	T4	135°C
2329.84	1647.42	MVE 13000/1	MVE 13000/12	13009	13246	422.2	375.6	10.00	10.00	17.00	16.00	6.20	6.3	M32	T4	135°C
2253	1550	MVE 12000/1	MVE 12000/12	12580	12466	522	476	7.99	9.50	15.00	15.00	5	5.5	M32	-	135°C
2634	1856	MVE 15000/1	MVE 15000/12	14706	14923	672	630	10.09	12.00	18.00	18.00	5.8	5.8	M32	-	135°C
3220	2147	MVE 17500/1	MVE 17500/12	17980	17264	744	684	11.92	14.20	21.00	21.00	5.6	5.9	M32	-	135°C
3632	2525	MVE 19500/1	MVE 19500/12	20285	20299	768	728	11.96	14.50	24.00	24.00	5.4	5.6	M32	-	135°C
4067	2622	MVE 22000/1	MVE 22000/12	22711	21079	916	868	13.95	17.00	28.00	28.00	4.8	5.3	M32	-	135°C
4572	3163	MVE 25000/1	MVE 25000/12	25532	25432	994	937	13.95	17.00	28.00	28.00	4.8	5.3	M32	-	135°C



**ДО РАЗМЕРА 60 (НЕ ВКЛЮЧАЯ РАЗМ. 60)**  
дебалансы 60Гц = дебалансы 50Гц,  
установленные на 70%



**СВЫШЕ 60 РАЗМЕРА (ВКЛЮЧИТЕЛЬНО)**  
Удельные дебалансы для 60 Гц.

Для перевода кг в Ньютоны:  $N = 9.81 \cdot kg$

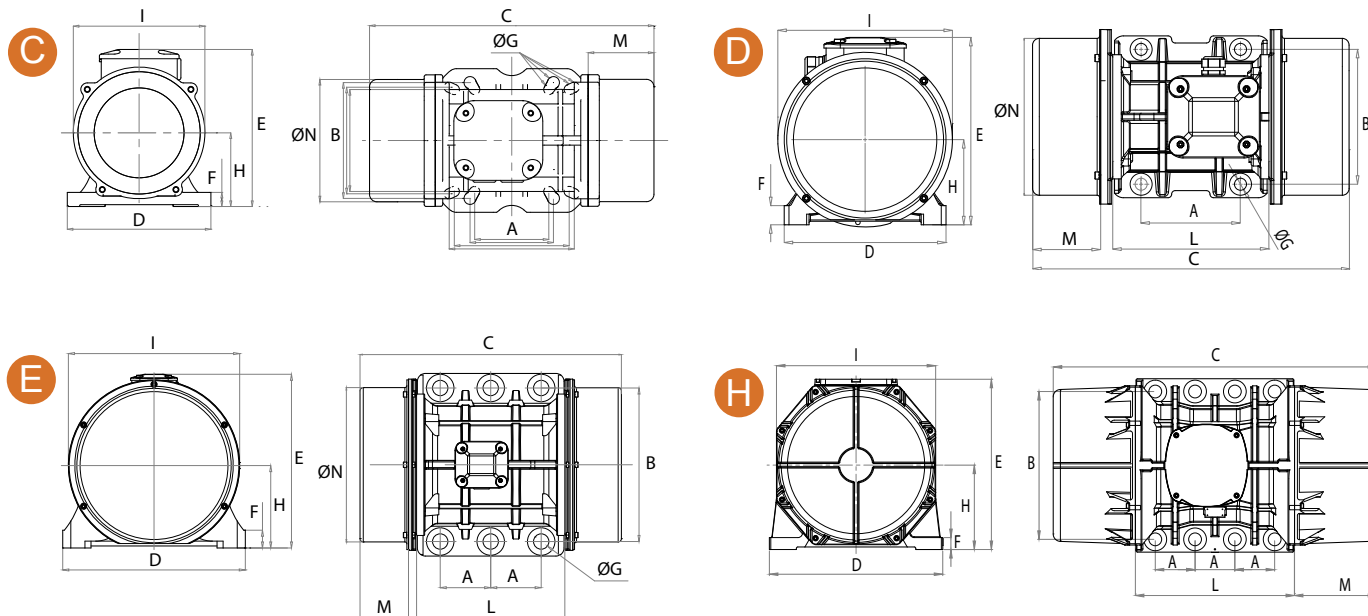

Модель		Чертеж	Размер	РАЗМЕРЫ (мм)														
50Hz	60Hz			C		M		A	B	ØG	Отверст. кол-во	D	E	F	H	I	L	N
				50Hz	60Hz	50Hz	60Hz	Измен. опорн. поверхн-ть										
MVE 50/1	MVE 50/12	C	30	273		55		80	110	11	4	154	175	15	79	142	163	131
MVE 100/1	MVE 100/12	C	30	303		70		90	125	13	4	154	175	15	79	142	163	131
MVE 200/1	MVE 200/12	D	40	334		78		124	110	11	4	168	196	22	92	169	178	158
MVE 300/1	MVE 300/12	D	50	391		93		135	115	11	4	208	210	22	94	180	205	170
MVE 500/1	MVE 500/12	D	50	451		123		120	170	17	4	208	210	22	94	180	205	170
MVE 510/1	MVE 510/12	D	50	451		123		120	170	17	4	208	210	22	94	180	205	170
MVE 800/1	MVE 800/12	D	60	446		96		140	190	17	4	229	262	30	120	247	220	222
MVE 1100/1	MVE 1100/12	D	60	510	446	129	96	140	190	17	4	229	262	30	120	247	220	222
MVE 1500/1	MVE 1500/12	D	60	562	510	154	129	140	190	17	4	229	262	30	120	247	220	222
MVE 1600/1	MVE 1600/12	D	70	556	522	140	123	155	225	22	4	272	295	40	140	267	250	235
MVE 2100/1	MVE 2100/12	D	70	616	556	170	140	155	225	22	4	272	295	40	140	267	250	235
MVE 2600/1	MVE 2600/12	D	75	708	588	200	140	155	255	23.5	4	302	318	35	147	295	273	264
MVE 3000/1	MVE 3000/12	D	75	708	608	200	150	155	255	23.5	4	302	318	35	147	295	273	264
MVE 5210/1	MVE 5210/12	E	78	794		242		105	248	22	6	300	335	30	163	305	310	284
MVE 3800/1	MVE 3800/12	D	80	683	603	170	130	180	280	26	4	332	360	37	167	345	304	310
MVE 4700/1	MVE 4700/12	D	80	733	683	195	170	180	280	26	4	332	360	37	167	345	304	310
MVE 5200/1	MVE 5200/12	D	85	688	605	160	120	200	320	28	4	378	411	49	200	424	325	378
MVE 6500/1	MVE 6500/12	D	85	688		160		200	320	28	4	378	411	49	200	424	325	378
MVE 8000/1	MVE 8000/12	D	85	788	688	210	160	200	320	28	4	378	411	49	200	424	325	378
MVE 9000/1	MVE 9000/12	D	85	788	688	210	160	200	320	28	4	378	411	49	200	424	325	378
MVE 10000/1	MVE 10000/12	E	90	826		210		125	380	39	6	452	430	44	204	422	367	378
MVE 13000/1	MVE 13000/12	E	90	926	826	260	210	125	380	39	6	452	430	44	204	422	367	378
MVE 12000/1	MVE 12000/12	E	100	1020		275		140	440	45	6	530	484	37	232	446	470	424
MVE 15000/1	MVE 15000/12	H	105	980		210		140	480	45	8	570	542	48	268	510	560	490
MVE 17500/1	MVE 17500/12	H	105	1060		250		140	480	45	8	570	542	48	268	510	560	490
MVE 19500/1	MVE 19500/12	H	105	1060		250		140	480	45	8	570	542	48	268	510	560	490
MVE 22000/1	MVE 22000/12	H	110	1130		285		140	520	45	8	610	594	42	297	560	560	530
MVE 25000/1	MVE 25000/12	H	110	1130		285		140	520	45	8	610	594	42	297	560	560	530

Размеры с грубой степенью точности относятся к UNI 22768/1

Данная информация предоставляется без какой-либо гарантии, без описаний, принуждения или лицензии. Информация была собрана в результате исследований, проводимых компанией OLI, или же получена из достоверных источников. Компания OLI не несет юридической ответственности за информацию.

СТАНДАРТ

ПОВЫШЕННАЯ  
БЕЗОПАСНОСТЬ

ВЗРЫВО-  
ЗАЩИТА

HI-STROKE  
MILLING